

The Role of Mechanistic PKPD Modeling in Explaining Variability in Efficacy Outcomes for Biosimilars

Wojciech Krzyzanski, PhD MA

Outline

- PKPD models and variability of PD markers of efficacy
- Pharmacodynamics mediated drug disposition
- Zarxio: PDMDD model for filgrastim
- Binocrit: PDMDD model for epoetin alfa
- PDMDD model for romiplostim

Utility of PKPD Modeling for Biosimilarity Analysis

- Calculation of subject number for clinical trials
- Dose selection
- Identification and quantification of sources of variability

Factors Contributing to Variability of Efficacy Markers

- Explained variability by mathematical and statistical model
 - using observable variables (covariates), e.g.

$$CL = CL_0 \left(\frac{BW}{BW_0} \right)^{0.75}$$

-using variables that are not observable, e.g.

$$CL_{tot} = k_{el}V + \frac{k_{int}R_{tot}V}{K_D + C}$$

- Unexplained variability (residual variability)

Concept of Pharmacodynamics Mediated Drug Disposition

Pharmacodynamics mediated drug disposition (PDMDD) is a special case of target mediated drug disposition where pharmacodynamics (e.g., cell count) affects the size of the target (e.g. receptor) pool and, consequently, influences the target-mediated clearance.

Cell-Level Model of PDMDD

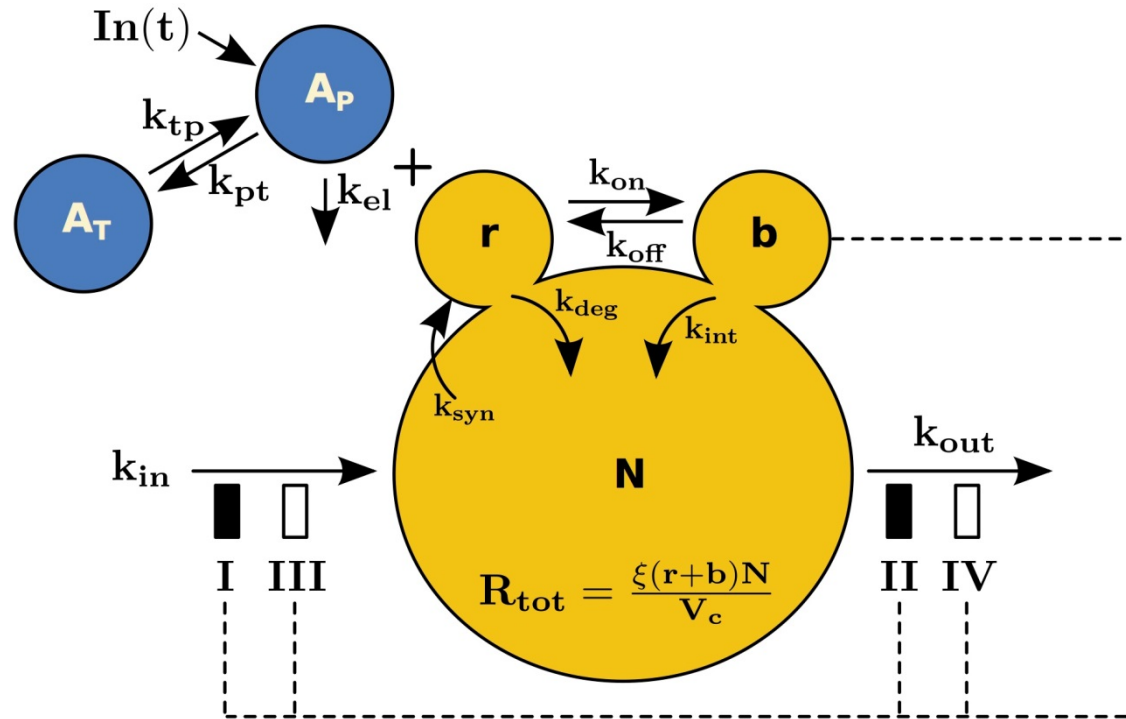

r - free receptors per cell.
 b - bound receptors per cell.
 N - number of cell.

Drug Plasma Concentration: Repeated Doses

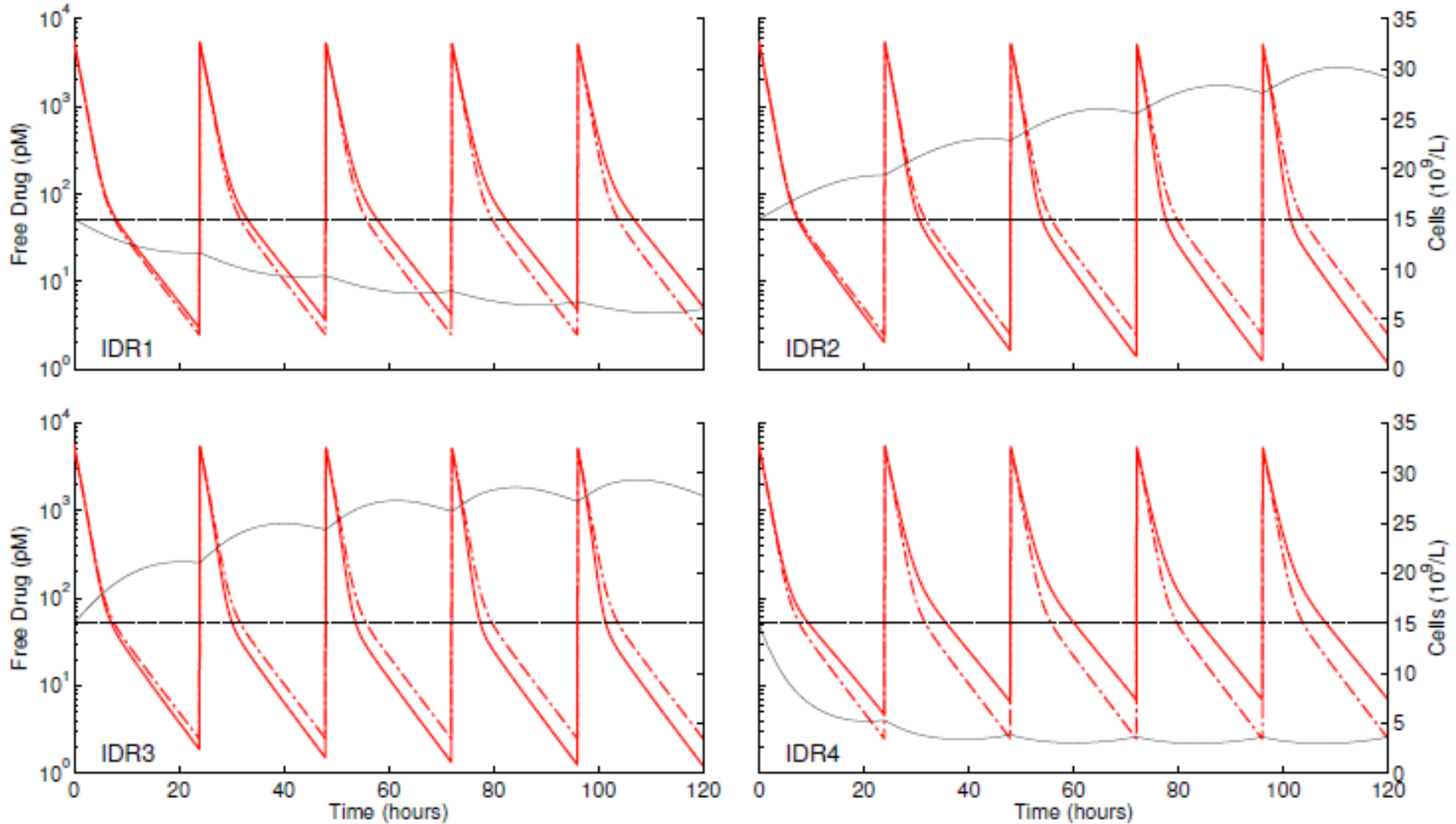

Dashed lines represent model with no effect on cell turnover.

Zarxio: Biosimilar for Neupogen

- Zarxio is produced by Sandoz, a Novartis company
- Zarxio was approved first in the EU in 2009 and is marketed in most countries of the European Economic Area (as Zarzio) as well as in 32 additional countries worldwide
- Zarxio has been confirmed to be biosimilar to the reference product, US-licensed Neupogen
- Biosimilarity studies included:
 - five animal studies to assess pharmacodynamics, toxicity, toxicokinetics, and local tolerance
 - one pivotal and four supportive studies comparatively assessing the pharmacokinetics and pharmacodynamic effects of Zarxio and Neupogen;
 - a pivotal clinical trial in breast cancer patients to demonstrate non-inferiority in clinical effectiveness
- Primary efficacy endpoint: duration of neutropenia

Biology of G-CSF

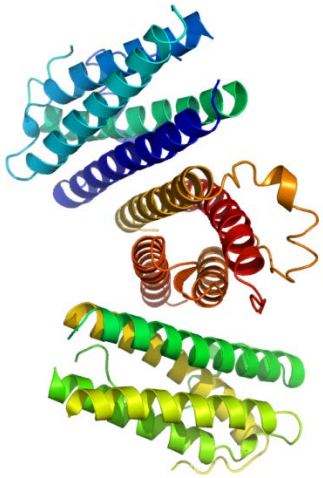

- **G-CSF** is 20 kD cytokine that stimulates proliferation neutrophil progenitors into mature neutrophils and enhances release of neutrophils from the bone marrow
- Produced by endothelial cells, fibroblasts, and microphages
- The receptor-mediated binding of the G-CSF followed by internalization and glomerular filtration and subsequent renal metabolism are major clearance mechanisms
- **G-CSFR** is a 130 kD member of the class 1 cytokine receptor superfamily
- Expressed on bone marrow progenitor cells and neutrophils, monocytes, platelets, endothelial cells
- 500-1200 receptors per neutrophil, KD \sim 10-2000 pM, internalization rate \sim 2-4 h⁻¹

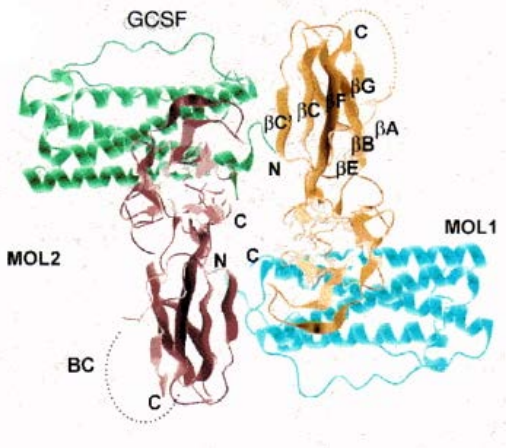

Population Modeling of Filgrastim PK-PD in Healthy Adults Following Intravenous and Subcutaneous Administrations

- Four clinical trials in healthy volunteers:
 - SC 10 $\mu\text{g}/\text{kg}$ QD for 7 days (N=16)
 - SC 2.5 and 5 $\mu\text{g}/\text{kg}$ QD for 7 days (N=27)
 - IV 5 $\mu\text{g}/\text{kg}$ (N=12)
 - SC 1 $\mu\text{g}/\text{kg}$ (N=12)
- PK marker: G-CSF serum concentrations
- PD marker: Absolute Neutrophil Count

PDMDD Model for Filgrastim

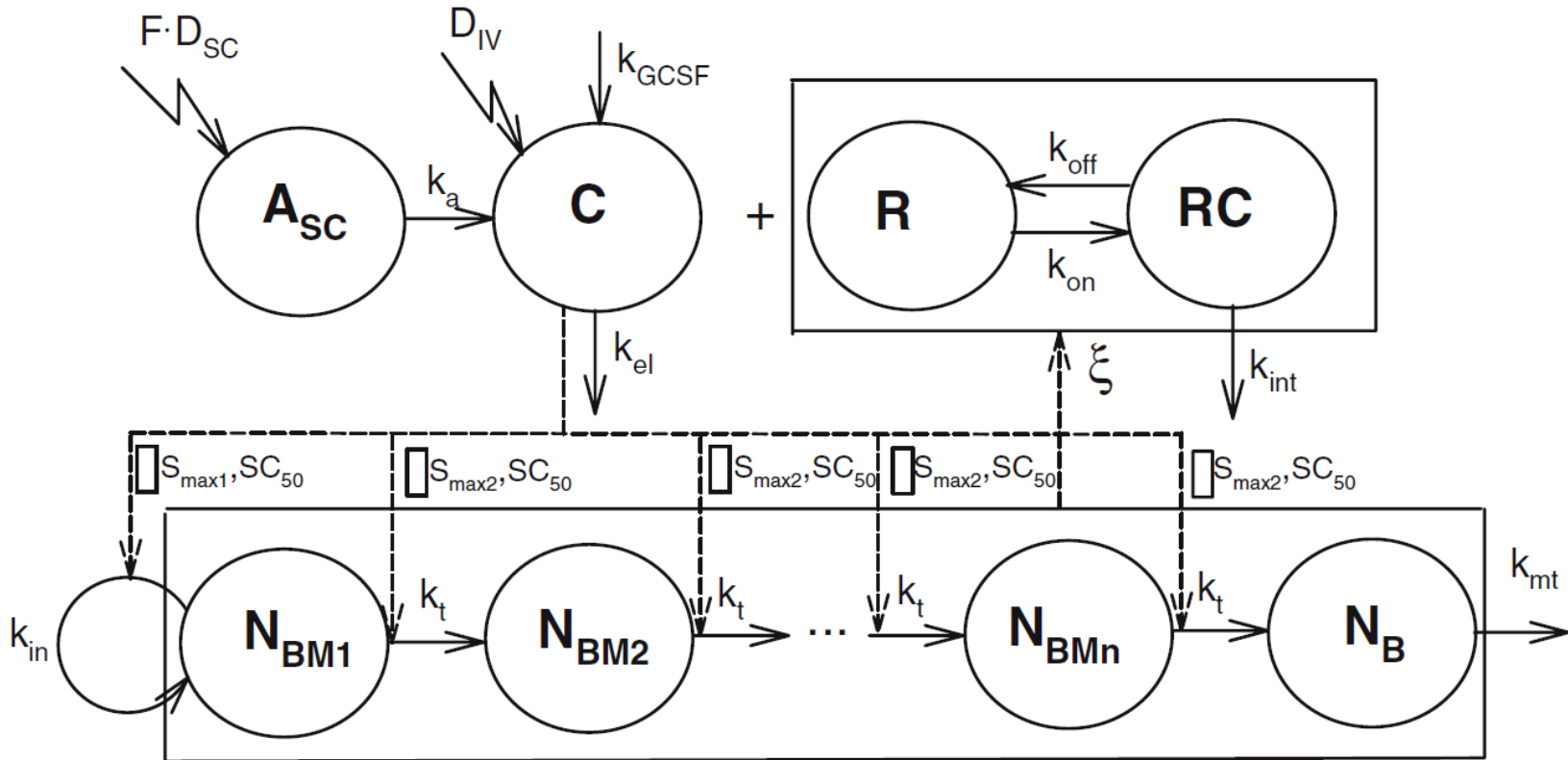

$$R_{tot} = \xi \cdot (N_{BM} + N_B)$$

Impact of Target Expression on Neutrophil Counts

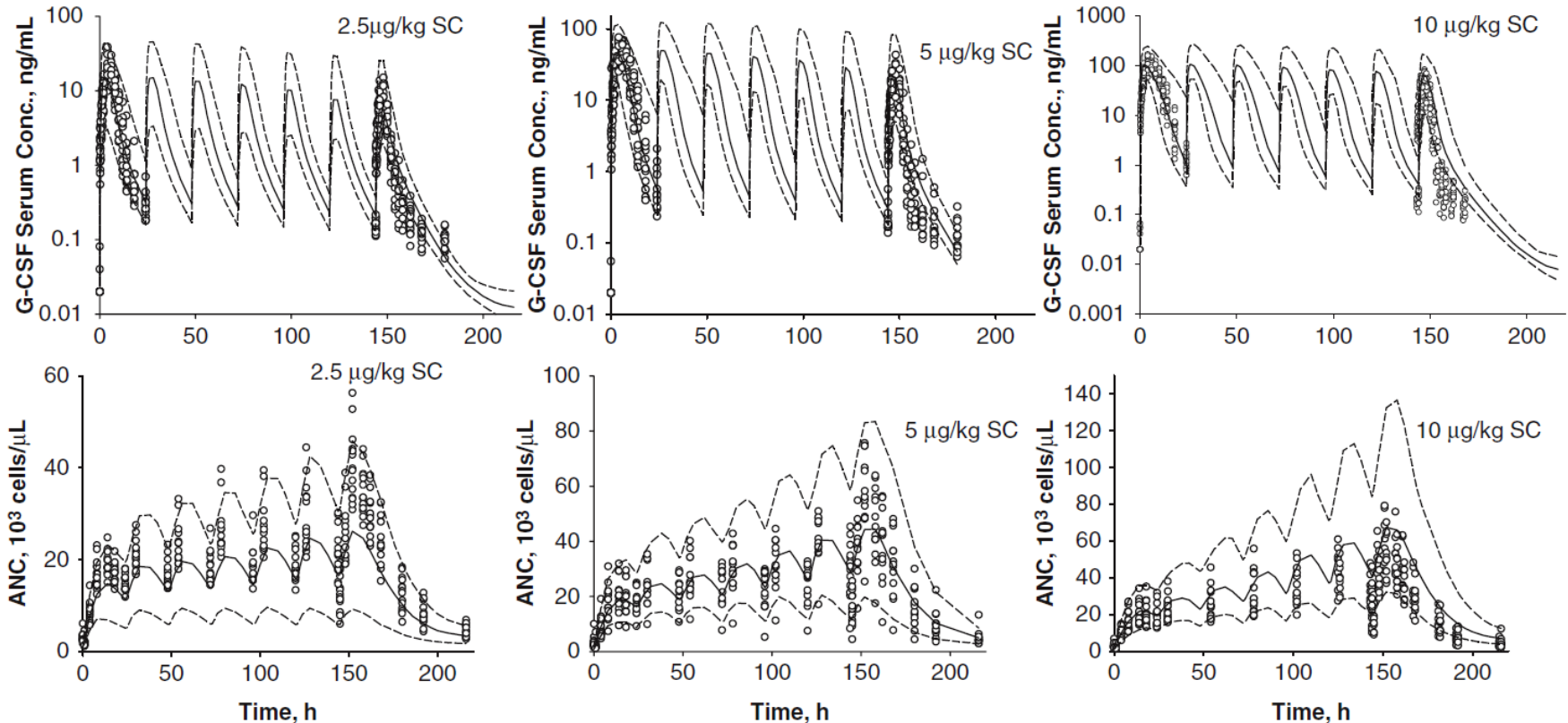

Time courses of filgrastim serum concentrations and ANCs (symbols) following multiple SC administrations of 2.5 μ g/kg (left), 5 μ g/kg (middle), and 10 μ g/kg (right). The lines represent the 5th, 50th, and 95th percentiles of model-predicted values.

Impact of Multiple G-CSF Dosing on Receptor Pool and Clearance

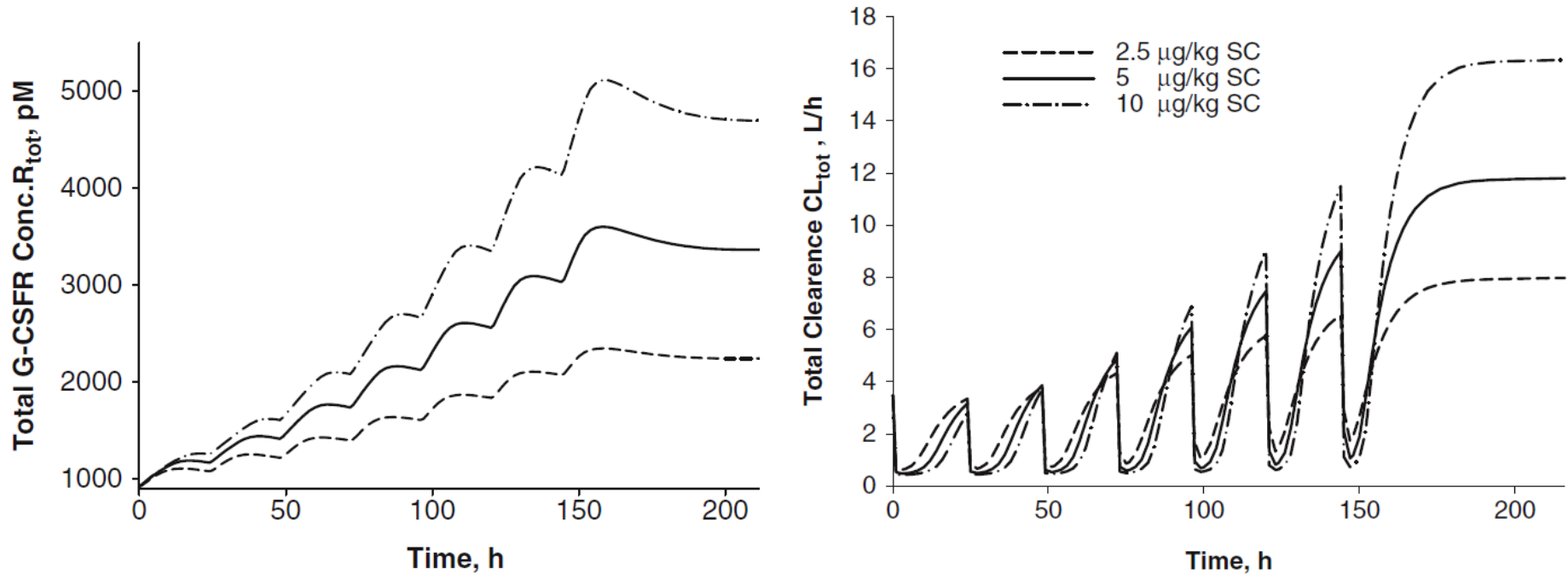

Simulated time profiles of total G-CSF receptor concentrations R_{tot} and total clearance following multiple SC administrations of 2.5, 5, and 10 µg/kg

Binocrit: Biosimilar for Epoetin Alfa

- Binocrit is manufactured by Sandoz
- Biosimilar product to the US-licensed reference product Eprex/Erypo (epoetin alfa)
- Approved by EMA in 2007 for treatment of chronic renal failure anemia
- Approval was based on data:
 - Two Phase III trials, parallel group, multiple IV (N=478) and SC (N=114) doses
 - Two trials in healthy volunteers, parallel group, multiple IV (N=76) and SC (N=74) doses
 - One trial in healthy volunteers, 2x2 crossover, single IV and SC dose (N=6)
- Primary efficacy endpoint: hemoglobin levels

Biology of EPO

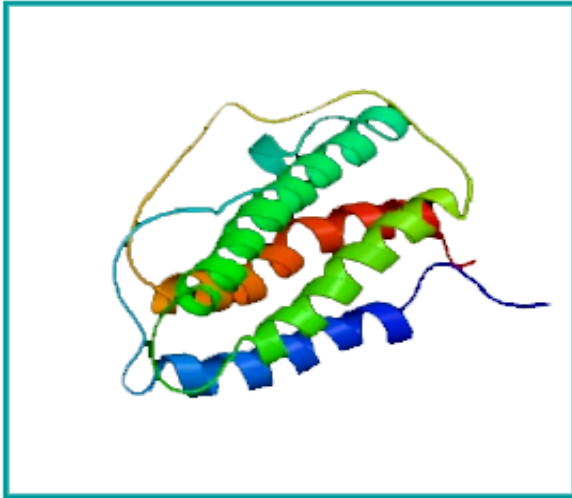

- **Erythropoietin (EPO)** is a 30.4 kD glycoprotein responsible for red blood cell production
- Synthesized by renal glomerular epithelial cells in response to tissue hypoxia
- Eliminated from the circulation mostly by binding to EPO receptors
- **Erythropoietin receptor (EPOR)** is a dimer of 85 kD, member of the class 1 cytokine receptor superfamily
- Expressed on erythroid progenitor cells, epicardium, neurons, liver, gut, endothelium
- Upon activation EPOR activates signaling pathways leading to inhibition of apoptosis, increased proliferation, and acceleration of maturation of erythroid cells in bone marrow

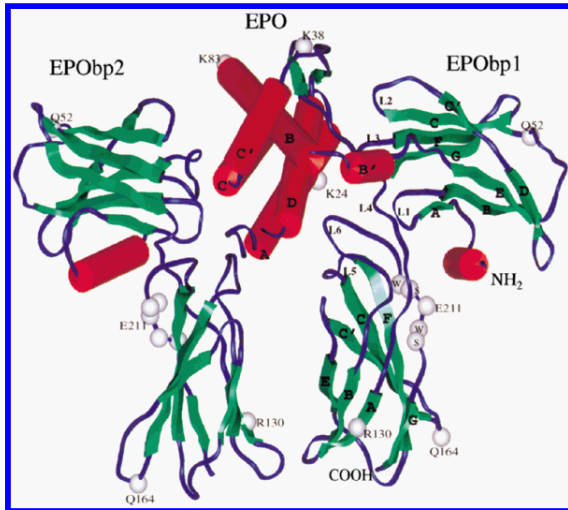

Population Pharmacokinetic and Pharmacodynamic Model-Based Comparability Assessment of a Recombinant Human Epoetin Alfa and the Biosimilar HX575

- Two clinical trials for bioequivalence of HX575 and recombinant human epoetin alfa
- Open-label, randomized, parallel design
- Healthy subjects (N = 74 and N=75)
- IV and SC 100 IU/kg t.i.w. for 4 weeks
- PKPD markers: EPO plasma concentrations, reticulocytes, RBCs, and hemoglobin

PDMDD Model for EPO

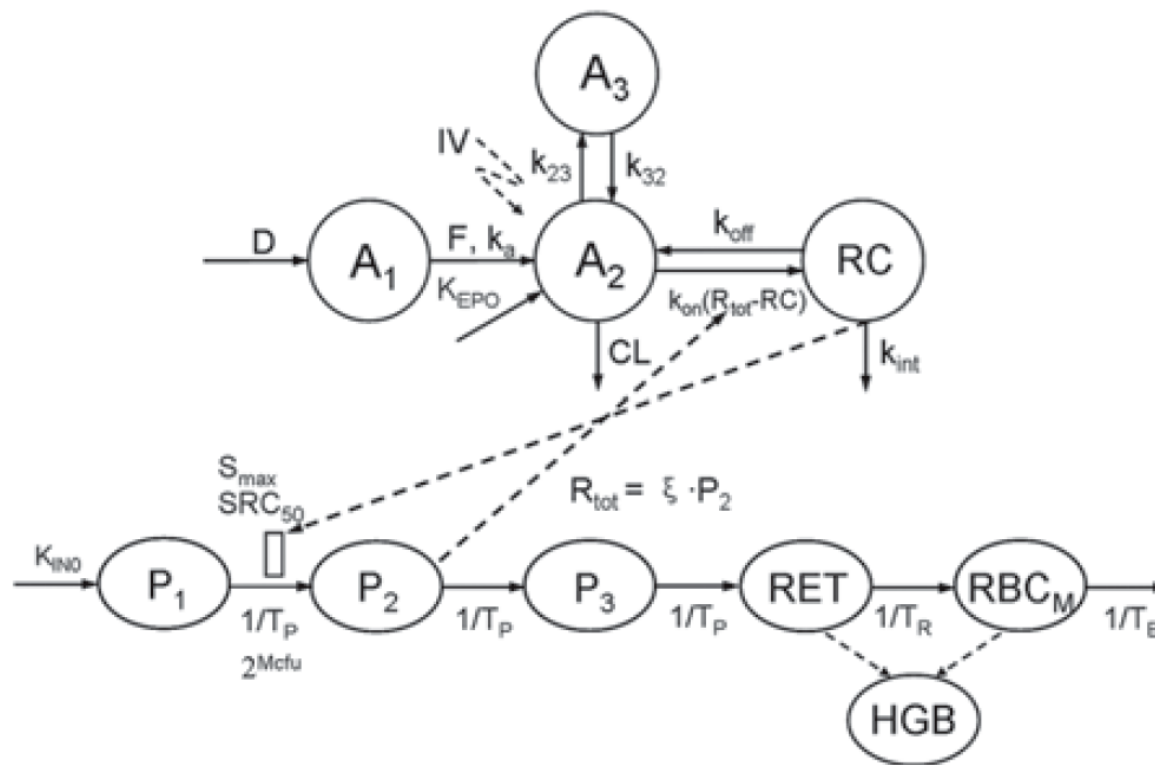

$$R_{tot} = \xi P_2$$

Concentration of total receptors is proportional to number of erythroid progenitor cells.

Impact of Target Expression on EPO PK and Hemoglobin

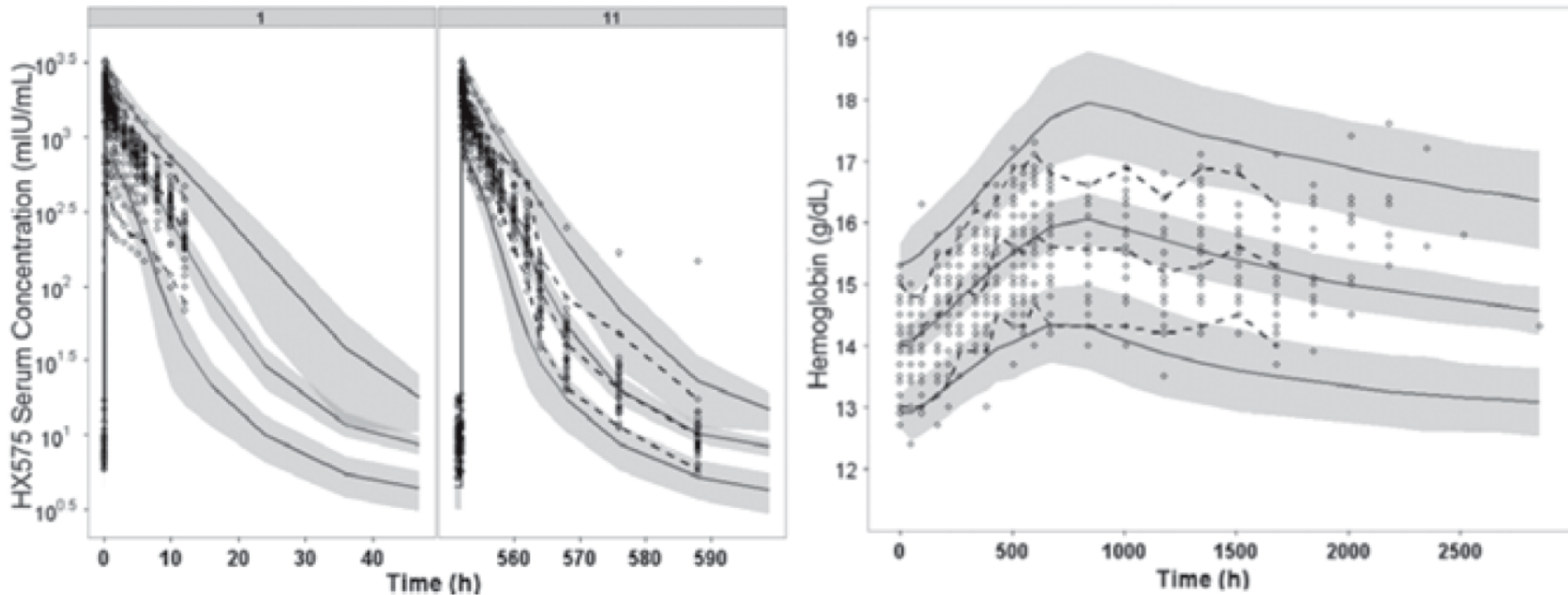

Serum HX575 concentrations and hemoglobin after the 1st and 11th doses. Open circles represent observed data. Dashed lines represent the 5th, 50th, and 95th percentiles of observed data. Solid lines represent the 5th, 50th, and 95th percentiles of simulated data.

90% CIs: Model vs NCA

Metrics	Model-Based Method		NCA Method ^a	
	T/R Ratio	90% CI	T/R Ratio	90% CI
AUC _{IV}	87.1	77.6-97.8	89.2	82.5-96.2
Cmax _{IV}	98.6	89.9-108.2	97.5	91.5-104.5
AUEC _{IV}	99.7	98.2-101.2	99.9	98.5-101.2
AUC _{SC}	93.7	82.7-106.2	96.9	88.2-106.5
Cmax _{SC}	95.8	83.4-110.0	97.6	84.2-113.1
AUEC _{SC}	99.6	98.0-101.2	98.9	97.7-100.2

Metrics estimates for PK/PD comparability analysis based on 500 data sets simulated from the model parameters compared to standard NCA results

Romiplostim (Nplate): Peptibody

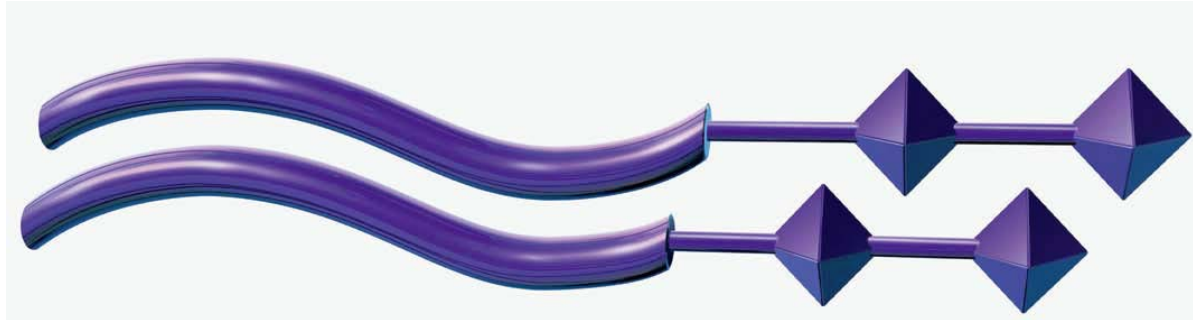

- Romiplostim is a thrombopoiesis-stimulating Fc-peptide fusion protein (peptibody) that contains 2 copies of the Fc portion of a human immunoglobulin, each of which is covalently linked to a peptide chain containing 2 thrombopoietin (TPO) receptor-binding peptides
- Similar to endogenous TPO, romiplostim activates the c-Mpl receptor to stimulate the growth and maturation of megakaryocytes, which ultimately result in increased production of platelet
- Romiplostim has no sequence homology with endogenous TPO

Biology of TPO

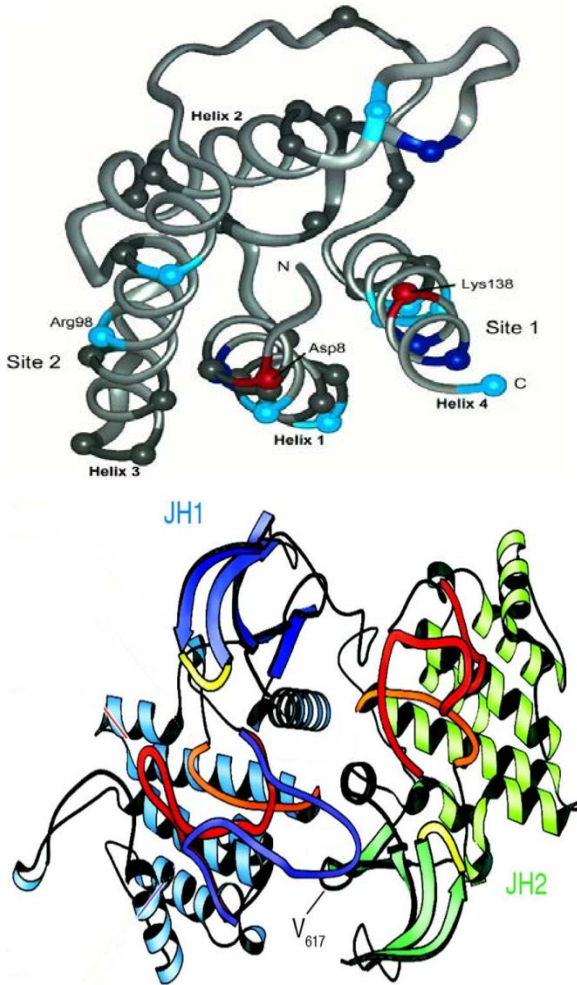

- **TPO** is a 70 kD glycoprotein that stimulates the proliferation, differentiation and maturation of megakaryocyte progenitors
- Produced primarily in liver parenchymal cells.
- Levels of TPO in blood are regulated by c-Mpl mass on platelets and megakaryocytes
- **c-Mpl** is 95 kD member of the class 1 cytokine receptor superfamily
- Expressed on platelets, megakaryocytes and CD34+ progenitor cells.
- Upon TPO binding c-Mpl is internalized and degraded, internalization rate $\sim 4 \text{ h}^{-1}$
- 25-100 receptors/platelet, $K_D \sim 100\text{-}900 \text{ pM}$

Pharmacodynamics-Mediated Drug Disposition (PDMDD) and Precursor Pool Lifespan Model for Single Dose of Romiplostim in Healthy Subjects

- Phase I study: randomized, double-blind, placebo-controlled, N=48 subjects
- 8 dosing groups: placebo, single IV (0.3, 1, 10 $\mu\text{g}/\text{kg}$), single SC (0.1, 0.3, 1, 2 $\mu\text{g}/\text{kg}$)
- Observed romiplostim serum concentrations and platelet counts

PDMDD Model for Romiplostim

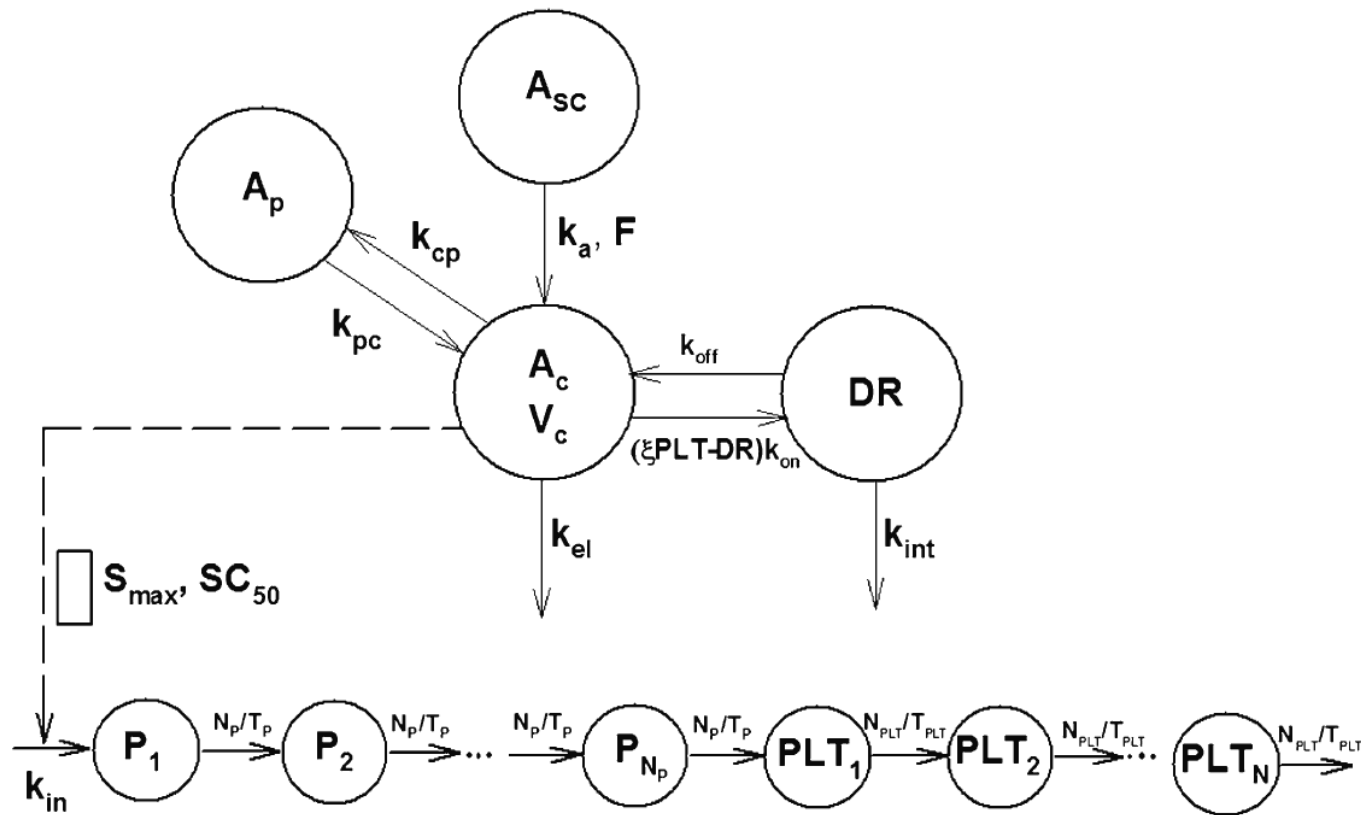

$$R_{tot} = \xi PLT$$

Concentration of total receptors is proportional to platelet count.

Impact of Target Expression on Platelet Count

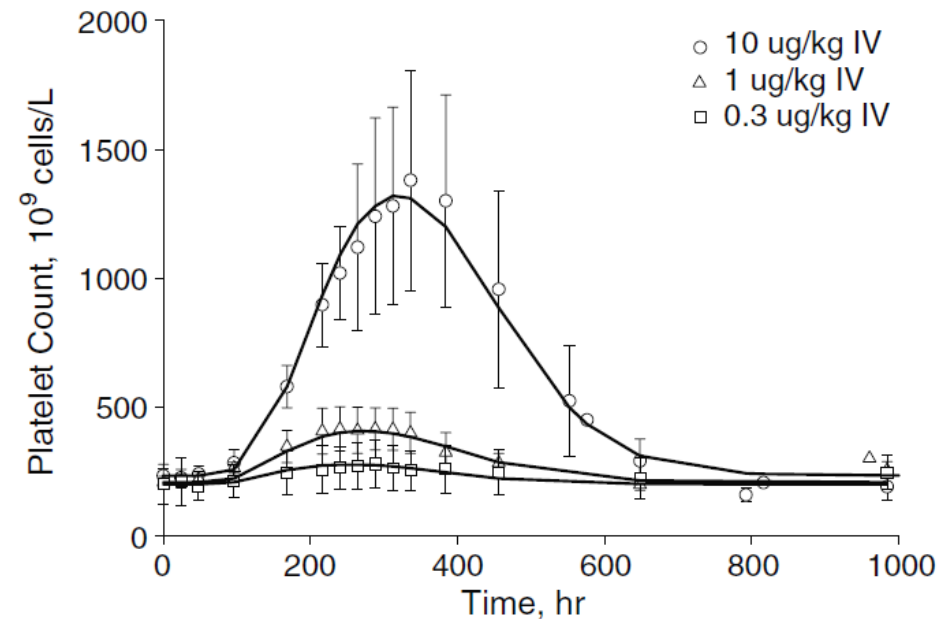
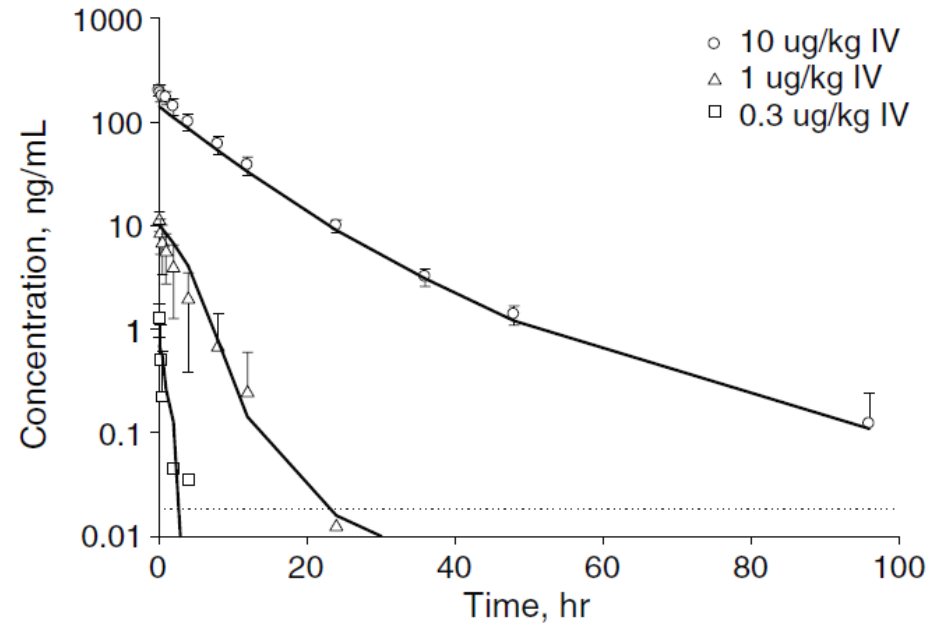

Mean observed data for romiplostim serum concentration and platelet count following single dose IV injection. Lines represent model predictions.

Effect of Baseline PLT on Romiplostim PK

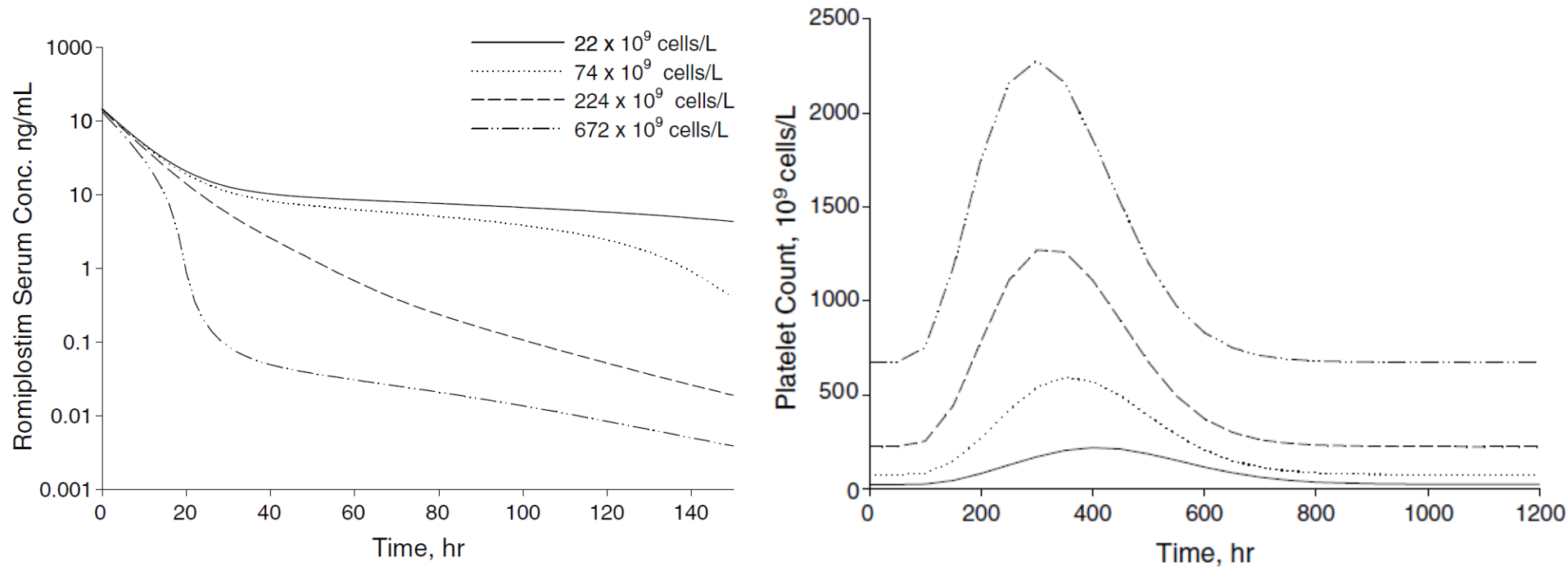

Simulated romiplostim serum concentrations and platelet counts following administration of a single IV dose of 10 $\mu\text{g}/\text{kg}$ in healthy subject

Conclusions

- PKPD modeling is particularly useful for quantification of variability of PK and PD markers that is controlled by time dependent variables that cannot be measured directly
- PDMDD is expected to be a factor for biologics exhibiting TMDD and targeting cell-bound receptors with MOA resulting in increase/decrease of cell pool
- Designs of clinical studies addressing biosimilarity to hematopoietic growth factors should take into account of increased variability of AUC, Cmax, and AUEC metrics due to PDMDD